

SA940CXA

smeg 90cm wallmount rangehood



dimensions	898mm W x 500mm D x 980mm H maximum
finish	stainless steel
installation	wallmount
motor	
capacity	900 <sup>3</sup> m/hr
noise rating	62 dBA
extraction	

illumination	1 x 7W strip LED lamp
speeds	three
delay stop	
cleaning prompt	
filtration	3 x stainless steel filters
option	carbon filter
warranty	two years parts and labour

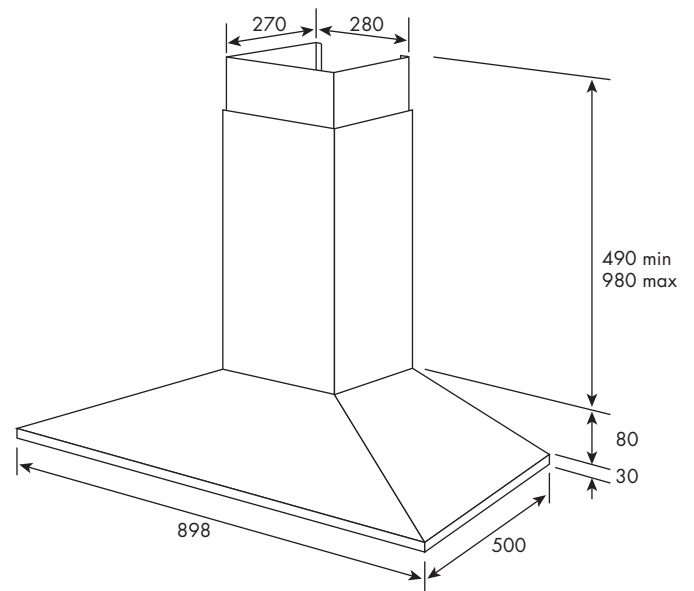

**PLEASE NOTE: drawings are not to scale. They are to assist only.**