

**90cm stainless steel dual fuel freestanding cooker with a 5 burner gas cooktop, electric multi-function 8 Twin Fan oven, 14.4 mj/h wok burner, 1 set telescopic runners, programmable timer and 125L gross capacity.**

RRP AUS \$2,799.00



## Product Details

### FEATURES

Twin Fan System	High powered 14MJ/h wok burner	Telescopic runners	Digital Programmable timer
Fast Heat Up	Cast iron trivets	Stainless steel	Large 125L gross oven capacity
Triple glazed oven door glass	Clip-on plinth included	Handy storage compartment Extra storage always comes in handy, so with a clever storage compartment you can easily stow away any extra pots and pans.	

### BENEFITS

**Twin fan system for even cooking**  
Cook each dish to perfection with the Twin Fan System. Fans rotate in opposite directions, distributing heat evenly throughout the oven, so you enjoy great results every time.

**Bring out the flavour with high heat**  
Whip up tasty stir-fries and more with our high-powered wok burner. You'll get the high heat you need with 14.4 MJ/h of power at its highest setting.

**Designed for ease and safety**  
Telescopic runners are another piece of thoughtful design that makes it easy to draw racks out and safely check on your dishes during cooking.

**All the room for all your family favourites**  
If you are serious about creating delicious family feasts and you love entertaining, you'll be right at home with our 90cm oven with a generous 125L gross capacity. That's plenty of room for the biggest Christmas turkey or a weekend roast for all the family. The extra width makes getting things in and out super easy.

Built in Australia

Westinghouse, has been the heart of the home for generations and the kitchen appliance brand we have always known and trusted to build reliable products. This oven is built in a local factory in Adelaide.

---

## Specifications

### PRODUCT PROFILE

---

Domestic warranty details (yrs)	2
---------------------------------	---

---

Oven fuel	electric
-----------	----------

---

Materials/Colour	mark resistant stainless steel
------------------	--------------------------------

---

Controls of Oven	control knob
------------------	--------------

---

Cooling fan	Yes
-------------	-----

---

Plinth colour (kickboard)	stainless steel
---------------------------	-----------------

---

Anti tilt plate	Yes
-----------------	-----

---

Front/rear controls	front
---------------------	-------

---

### MAIN OVEN

---

Gross capacity litres	125
-----------------------	-----

---

Useable capacity litres	116
-------------------------	-----

---

Oven function	multifunction
---------------	---------------

---

Number of functions	8
---------------------	---

---

### DIMENSIONS

#### PRODUCT DIMENSION

---

Total height (mm)	910
-------------------	-----

---

Total width (mm)	895
------------------	-----

---

Total depth (mm)	600
------------------	-----

---

### ELECTRICAL CONNECTION

---

Connected load KW	3.6
-------------------	-----

---

Maximum current rating (amps)	15
-------------------------------	----

---

Type of connection	hardwired
--------------------	-----------

---

## MAIN OVEN

---

Oven liner	pyrolux high temperature enamel
------------	---------------------------------

---

Timer functions	duration,end,minute minder,oven start,Countdown,24 hour clock
-----------------	---

---

Lights	2
--------	---

---

Light wattage	25
---------------	----

---

Light position	top
----------------	-----

---

Light activation by door	Yes
--------------------------	-----

---

Layers of glass in door	3
-------------------------	---

---

Telescopic runners	one
--------------------	-----

---

Shelf support	Easy glide side racks
---------------	-----------------------

---

Number of shelves	2
-------------------	---

---

Number of shelf positions	5
---------------------------	---

---

Closed door grilling	Yes
----------------------	-----

---

## SHIPPING

---

Shipping Weight (Kg)	82
----------------------	----

---

## STUFFING QUANTITIES

---

20ft	32
------	----

---

## SHIPPING

---

Pack Dimensions Height (mm) 900

---

Pack Dimension Width (mm) 1000

---

Pack Dimension Depth (mm) 750

---

## COOKTOP (IF APPLICABLE)

---

### PRODUCT PROFILE

---

Cook top type gas

---

Materials/Colour stainless steel

---

Knob finish metalised

---

## LEFT REAR ZONE

---

Left rear zone semi-rapid

---

## CONTROLS

---

Position of controls front

---

## STUFFING QUANTITIES

---

40ft 64

---

40ft HC 90

---

## ELEMENTS/BURNERS

---

Cooking zones 5

---

## FEATURES

---

Trivets cast iron

---

Ignition type electronic

---

## GAS SPECIFICATIONS

---

Maximum gas rating (NG) 49.4

---

Position of connection

rear right

---

## Dimensions

WFE915SD,  
WFE916DSD,  
WFEP917DSD

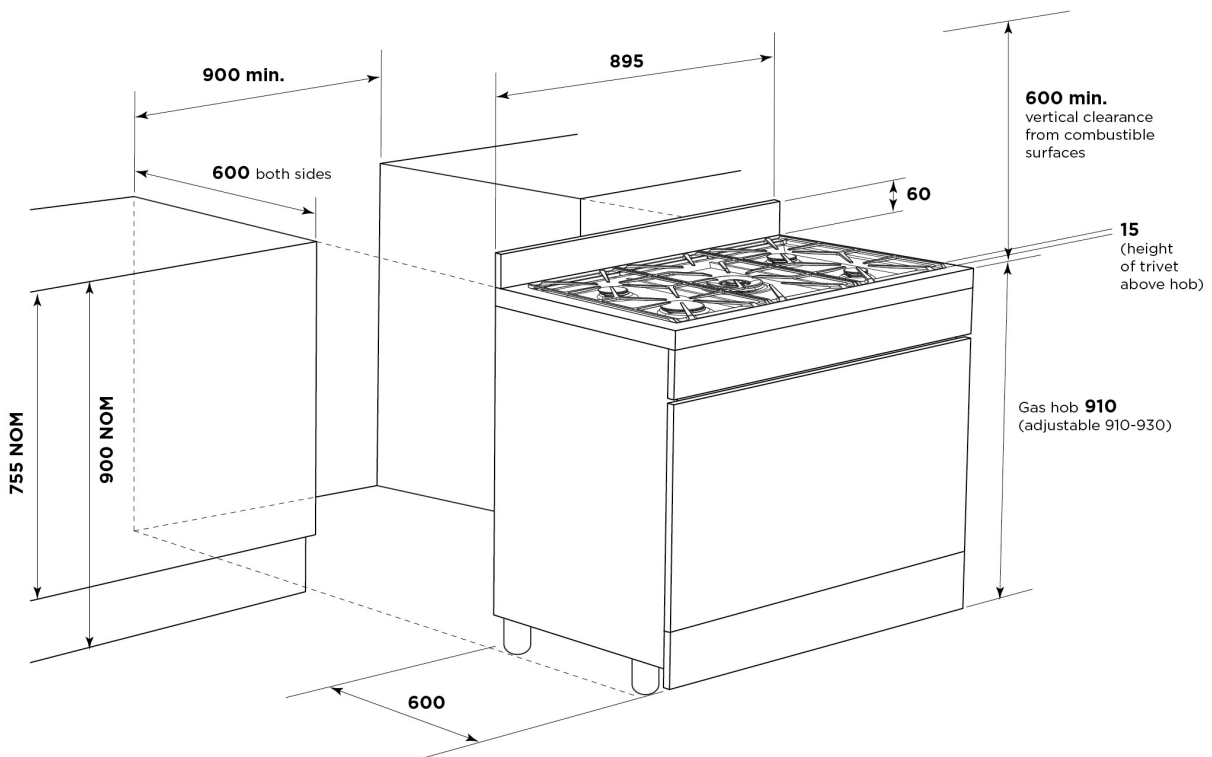

### IMPORTANT

These dimensions are a guide only. All measurements are in millimetres (mm).  
For complete installation instructions, refer to the manual provided with product.



# Terms and Conditions

## IMPORTANT

This is a guide of product dimensions only. For complete installation instructions, refer to the manual provided with product.

## PRODUCT INFORMATION

The descriptors and illustrations in this publication apply to the specific products and models described as at the date of issue. Under our policy of continuous product development, product specifications may change without notice. Prospective purchasers should therefore check with their retailer to ensure this publication correctly describes the products that are being offered for sale. All information supplied is to be used for general reference purposes only and is on the understanding that Electrolux Home Products Pty Ltd (Australia) and Electrolux (NZ) Ltd (New Zealand) will not be liable for any loss, liability or damage of whatever kind arising as a result of reliance on such information. Colours of products illustrated are as close as printing limitations allow. Electrolux will at all times comply with its obligations pursuant to law including Trade Practices (Australian Consumer Law) Act and Regulations.

## WARRANTY

This warranty only applies to Appliances purchased and used in Australia or New Zealand and used in normal domestic applications and is in addition to (and does not exclude, restrict, or modify in any way) any non-excludable statutory warranties in Australia or New Zealand. All warranties are subject to the conditions set out in the warranty card accompanying the product when purchased.

### ELECTROLUX HOME PRODUCTS AUSTRALIA

telephone: 1300 363 640

fax: 1800 350 067

email: [customercare@electrolux.com.au](mailto:customercare@electrolux.com.au)

web: [www.electrolux.com.au](http://www.electrolux.com.au)

### ELECTROLUX HOME PRODUCTS NEW ZEALAND

telephone: 09 573 2230

fax: 09 573 2221

email: [customercare@electrolux.co.nz](mailto:customercare@electrolux.co.nz)

web: [www.electrolux.co.nz](http://www.electrolux.co.nz)